



OPERATOR'S MANUAL & PARTS DRAWINGS

V-BLADE MODEL KV552





500 Venture Drive
PO Box 148
Orrville Oh 44667
www.ventrac.com

To the Owner
Contact Information and Product Identification

If you need to contact an authorized Ventrac dealer for information on servicing your product, always provide the product model and serial numbers.

Please fill in the following information for future reference. See the picture(s) below to find the location of the identification numbers. Record them in the spaces provided.

Date of Purchase: _____

Dealer: _____

Dealer Address: _____

Dealer Phone Number: _____

Dealer Fax Number: _____

Model # (A): _____
Serial # (B): _____

Affix Part/Serial Number label here.

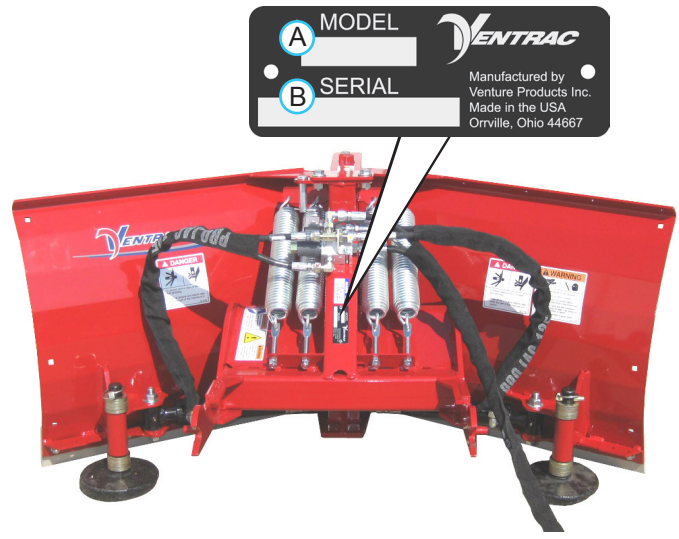

Venture Products Inc. reserves the right to make changes in design or specifications without obligation to make like changes on previously manufactured products.

TABLE OF CONTENTS

| | |
|--|----------------|
| INTRODUCTION | PAGE 5 |
| Product Description..... | 5 |
| Why Do I Need an Operator’s Manual? | 5 |
| Using Your Manual..... | 6 |
| Manual Glossary | 6 |
| SAFETY | PAGE 7 |
| Safety Decals..... | 7 |
| General Safety Procedures..... | 9 |
| Training Required..... | 9 |
| Personal Protective Equipment Requirements | 9 |
| Operation Safety | 9 |
| Preventing Accidents..... | 10 |
| Keep Riders Off..... | 10 |
| Operating On Slopes..... | 11 |
| Roadway Safety | 11 |
| Truck Or Trailer Transport | 11 |
| Maintenance..... | 12 |
| Fuel Safety | 12 |
| Hydraulic Safety | 13 |
| OPERATIONAL CONTROLS | PAGE 15 |
| Operational Control Locations..... | 15 |
| Blade Trip Control | 15 |
| Blade Wing Angle..... | 15 |
| Blade Wing Selection | 15 |
| GENERAL OPERATION | PAGE 16 |
| Daily Inspection..... | 16 |
| Attaching | 16 |
| Detaching..... | 16 |
| Operating Procedure..... | 16 |
| Transport of V-blade..... | 17 |
| Blade Wing Angle Adjustment..... | 17 |
| Resetting the Blade Safety Trip..... | 17 |
| Skid Shoe Adjustment..... | 17 |
| SERVICE | PAGE 18 |
| Cleaning and General Maintenance..... | 18 |
| Cutting Edge Reversal/Replacement..... | 18 |
| Skid Shoe Replacement..... | 18 |
| Leveling Blade - Side to Side..... | 18 |
| Leveling Blade - Front to Rear | 19 |
| Lubrication Locations | 19 |
| Maintenance Schedule..... | 20 |
| Maintenance Checklist..... | 20 |

TABLE OF CONTENTS

| | |
|---|----------------|
| SPECIFICATIONS | PAGE 21 |
| Dimensions | 21 |
| Features | 21 |
| PARTS | PAGE 22 |
| Blade Wings, Cutting Edge, & Skid Shoes..... | 22 |
| Center Frame & Hitch Frame | 24 |
| Safety Trip Pivot & Springs | 26 |
| Hydraulic Cylinders, Hoses, & Solenoid Valve..... | 28 |
| 70.8044 Snow Containment Flap..... | 30 |
| 70.8048 Polyurethane Cutting Edge | 31 |
| 70.8045 6" Top Flare Extension | 32 |
| 70.8047 6" Straight Edge Extension | 33 |
| 70.8046 6" Extension with 6" Top Flare..... | 34 |
| WARRANTY | PAGE 35 |

INTRODUCTION



Venture Products Inc. is pleased to provide you with your new Ventrac KV552 V-blade! We hope that Ventrac equipment will provide you with a ONE Tractor Solution.

Listed below are just some of the items that can provide you *versatility* as you use your KV552. Please visit our web site, or contact your authorized Ventrac dealer for a complete list of items available for your new KV552 V-blade.

| KV552 Accessories | Item Description | Part Number |
|----------------------|------------------------------------|-------------|
| | Snow Containment Belt Kit | 70.8044 |
| | 6" Top Flare Extension Kit | 70.8045 |
| | 6" Extension with 6" Top Flare Kit | 70.8046 |
| | 6" Straight Edge Extension Kit | 70.8047 |
| | Polyurethane Cutting Edge Kit | 70.8048 |

Product Description

The KV552 V-blade is designed for the sole purpose of snow removal and moving loose materials. The KV552 V-blade is an excellent tool for snow removal with all the capabilities of a conventional blade, plus the added versatility of sweeping both wings back for single pass clearing of sidewalks or sweeping both wings forward to clear large areas without the need for repeated cleanup passes.

Each blade wing can be angled forward or backward 30 degrees using the power unit's secondary S.D.L.A. lever. The angle of each wing is controlled independently with a 12 volt electro-hydraulic valve activated by a switch on the power unit. The power unit must be equipped with a 12 volt switch & plug kit*.

Why Do I Need an Operator's Manual?

This manual has been created to help you gain the important knowledge of what is needed to safely operate, maintain, and service your machine. It is divided into sections for convenient reference of the appropriate section.

You must read and understand the operator's manual for each piece of Ventrac equipment you own. Reading the operator's manual will help you become familiar with each specific piece of equipment. Understanding the operator's manual will help you, as well as others, avoid personal injury and/or damage to the equipment. Keep this manual with the machine at all times. The manual should remain with the machine even if it is sold. If this manual becomes damaged or unreadable, it should be replaced immediately. Contact your local Ventrac dealer for a replacement.

When using a Ventrac attachment, be sure to read and follow the safety and operating instructions of both the power unit and the attachment being used to ensure the safest operation possible.

The information in this manual provides the operator with the safest procedures to operate the machine while getting the maximum use out of the unit. Failure to follow the safety precautions listed in this manual may result in personal injury and/or damage to the equipment.

*The power unit **must be** equipped with a 12 volt front switch & plug. Refer to your power unit operator's manual for the proper 12 volt front kit for your power unit.

INTRODUCTION

Using Your Manual

Throughout this manual, you will encounter special messages and symbols that identify potential safety concerns to help you as well as others avoid personal injury or damage to the equipment.

SYMBOL DEFINITIONS



ATTENTION

This symbol identifies potential health and safety hazards. It marks safety precautions. Your safety and the safety of others is involved.

There are three signal words that describe the level of safety concern: Danger, Warning, and Caution. Safety should always be the #1 priority when working on or operating equipment. Accidents are more likely to occur when proper operating procedures are not followed or inexperienced operators are involved.

Note: Right-Hand and Left-Hand orientations may be referred to at different places throughout this manual. Right-Hand and Left-Hand is determined as if sitting on the power unit seat facing forward.

SIGNAL WORD DEFINITIONS

⚠ DANGER

Indicates an imminently hazardous situation which, if not avoided, will result in death or serious injury. This signal word is limited to the most extreme cases.

⚠ WARNING

Indicates a potentially hazardous situation which, if not avoided, could result in death or serious injury.

⚠ CAUTION

Indicates a potentially hazardous situation which, if not avoided, may result in minor or moderate injury and/or property damage. It may also be used to alert against unsafe practices.

Manual Glossary

Power Unit A Ventrac tractor or other Ventrac engine powered device that may be operated by itself or with an attachment or accessory.

Attachment A piece of Ventrac equipment that requires a Power Unit for operation.

Accessory A device that attaches to a Power Unit or Attachment to extend its capabilities.

Machine Describes any "Attachment" or "Accessory" that is used in conjunction with a power unit.

SAFETY

Safety Decals

The following safety decals must be maintained on your KV552 V-blade.

Keep all safety decals legible. Remove all grease dirt, and debris from safety decals and instructional labels. If any decals are faded, illegible, or missing, contact your dealer promptly for replacements.

When new components are installed, be sure that current safety decals are affixed to the replacement components.

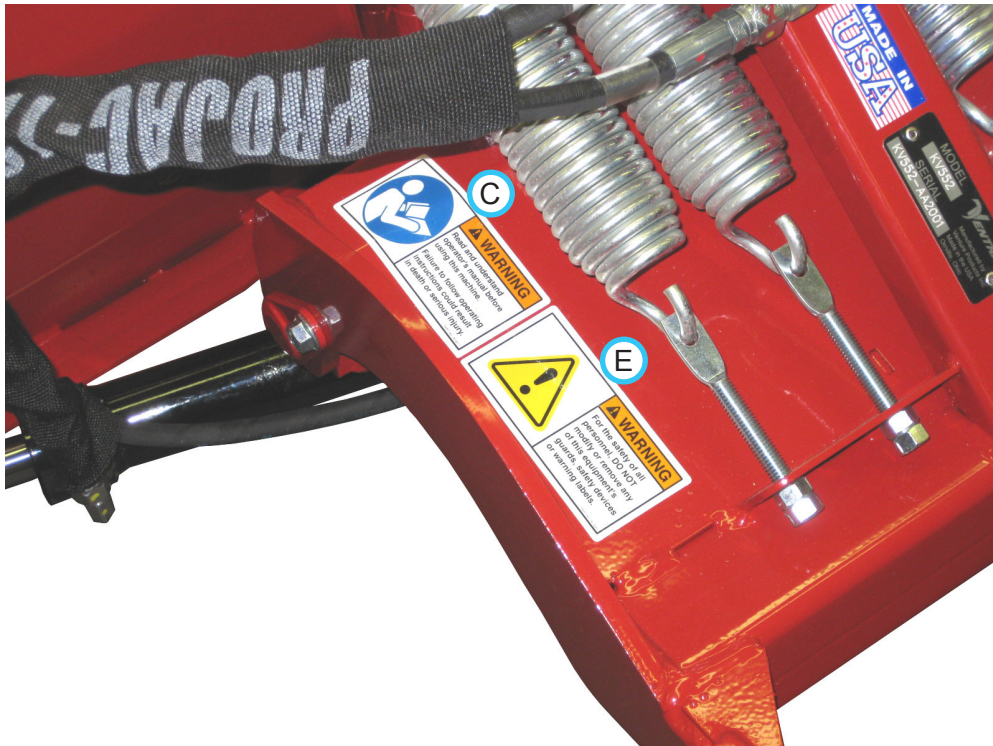

SAFETY

A

! DANGER



To prevent serious injury or death from pinching:

- **Keep all persons and objects clear while any part of this machine is in motion.**

00.0102

B

! WARNING



HIGH-PRESSURE FLUID HAZARD

To prevent serious injury or death:

- Relieve pressure on system before repairing or adjusting or disconnecting.
- Wear proper hand and eye protection when searching for leaks. Use wood or cardboard instead of hands.
- Keep all components in good repair

00.0103

C



! WARNING

Read and understand operator's manual before using this machine.

Failure to follow operating instructions could result in death or serious injury.

PART NO. 00.0217

D



! WARNING

Pinch Points.
Moving parts can crush or cut.
KEEP CLEAR!

E



! WARNING

For the safety of all personnel, **DO NOT** modify or remove any of this equipment's guards, safety devices or warning labels.

PART NO. 00.0220

| Decal | Description | Part Number | Quantity |
|-------|-------------------------------------|-------------|----------|
| A | Danger, Pinching Hazard | 00.0102 | 2 |
| B | Warning, High Pressure Fluid Hazard | 00.0103 | 1 |
| C | Warning, Read Owner's Manual | 00.0217 | 1 |
| D | Warning, Pinch Point | 00.0218 | 1 |
| E | Warning, General Safety | 00.0220 | 1 |

SAFETY



General Safety Procedures for Ventrac Power Units, Attachments, & Accessories



Training Required

- The owner of this machine is solely responsible for properly training the operators.
- The owner/operator is solely responsible for the operation of this machine and prevention of accidents or injuries occurring to him/herself, other people, or property.
- Do not allow operation or service by children or untrained personnel. Local regulations may restrict the age of the operator.
- Before operating this machine, read the operator's manual and understand its contents.
- If the operator of the machine cannot understand this manual, then it is the responsibility of this machine's owner to fully explain the material within this manual to the operator.
- Learn and understand the use of all controls.
- Know how to stop the power unit and all attachments quickly in the event of an emergency.



Personal Protective Equipment Requirements

It is the responsibility of the owner to be sure that the operators use the proper personal protective equipment while operating the machine. Required personal protective equipment includes, but is not limited to, the following list.



- Wear a certified ear protection device to prevent loss of hearing.
- Prevent eye injury by wearing safety glasses while operating the machine.
- Closed toe shoes must be worn at all times.
- Long pants must be worn at all times.
- When operating in dusty conditions, it is recommended that a dust mask be worn.

Operation Safety

- Inspect machine before operation. Repair or replace any damaged, worn, or missing parts. Be sure guards and shields are in proper working condition and are secured in place. Make all necessary adjustments before operating machine.
- Some pictures in this manual may show shields or covers opened or removed in order to clearly illustrate any instructions. Under no circumstance should the machine be operated without these devices in place.
- Alterations or modifications to this machine can reduce safety and could cause damage to the machine. Do not alter safety devices or operate with shields or covers removed.
- Before each use, verify that all controls function properly and inspect all safety devices. Do not operate if controls or safety devices are not in proper working condition.
- Check parking brake function before operating. Repair or adjust parking brake if necessary.
- Observe and follow all safety decals.
- All controls are to be operated from the operator's seat only.
- Always wear a seat belt if the machine has a roll cage/bar installed and in upright position.
- Ensure the attachment or accessory is locked or fastened securely to the power unit before operating.
- Ensure that all bystanders are clear of the power unit and attachment before operating. Stop machine if someone enters your work area.
- Always be alert to what is happening around you, but do not lose focus on the task you are performing. Always look in the direction the machine is moving.
- Look behind and down before backing up to be sure of a clear path.
- If you hit an object, stop and inspect the machine. Make all necessary repairs before operating machine again.
- Stop operation immediately at any sign of equipment failure. An unusual noise can be a warning of equipment failure or a sign that maintenance is required. Make all necessary repairs before operating machine again.

SAFETY



General Safety Procedures for Ventrac Power Units, Attachments, & Accessories



Operation Safety (continued)

- If equipped with a high/low range feature, never shift between high and low range while on a slope. Always move the machine to level ground and engage the parking brake before shifting range.
- Do not leave machine unattended while it is running.
- Always park the machine on level ground.
- Always shut off engine when connecting attachment drive belt to the power unit.
- Never leave the operator's seat without lowering the attachment to the ground, setting the parking brake, shutting off the engine, and removing the ignition key. Make sure all moving parts have come to a complete stop before dismounting.
- Never leave equipment unattended without lowering the attachment to the ground, setting the parking brake, shutting off the engine, and removing the ignition key.
- Only operate in well-lit conditions.
- Do not operate when there is a risk of lightning.
- Never direct the discharge of any attachment in the direction of people, buildings, animals, vehicles, or other objects of value.
- Never discharge material against a wall or obstruction. Material may ricochet back towards the operator.
- Use extra caution when approaching blind corners, shrubs, trees, or other objects that may obscure vision.
- Do not run the engine in a building without adequate ventilation.
- Do not touch the engine or the muffler while the engine is running or immediately after stopping the engine. These areas may be hot enough to cause a burn.
- Do not change the engine governor settings or over-speed the engine. Operating engine at excessive speed may increase the hazard of personal injury.
- To reduce the hazard of fire, keep the battery compartment, engine, and muffler areas free of grass, leaves, and excessive grease.

Preventing Accidents



- Clear working area of objects that might be hit or thrown from machine.
- Keep people and pets out of mowing area.
- Know the work area well before operation. Do not operate where traction or stability is questionable.
- Reduce speed when you are operating over rough ground.
- Equipment can cause serious injury and/or death when improperly used. Before operating, know and understand the operation and safety of the power unit and the attachment being used.

- Do not operate machine if you are not in good physical and mental health, if you will be distracted by personal devices, or are under the influence of any substance which might impair decision, dexterity, or judgment.
- Children are attracted to machine activity. Be aware of children and do not allow them in the working area. Turn off the machine if a child enters the work area.

Keep Riders Off

- Only allow the operator on the power unit. Keep riders off.
- Never allow riders on any attachment or accessory.



SAFETY



General Safety Procedures for Ventrac Power Units, Attachments, & Accessories



Operating On Slopes

- Slopes can cause loss-of-control and tip-over accidents, which can result in severe injury or death. Be familiar with the emergency parking brake, along with the power unit controls and their functions.
- If power unit is equipped with a fold down roll bar, it must be locked in the upright position when operating on any slope.
- Use low range (if equipped) when operating on slopes greater than 15 degrees.
- Do not stop or start suddenly when operating on slopes.
- Never shift between high and low range while on a slope. Always move the power unit to level ground and engage the parking brake before shifting range or placing the power unit in neutral.
- Variables such as wet surface and loose ground will reduce the degree of safety. Do not drive where machine could lose traction or tip over.
- Keep alert for hidden hazards in the terrain.
- Stay away from drop-offs, ditches, and embankments.
- Sharp turns should be avoided when operating on slopes.
- Pulling loads on hills decreases safety. It is the responsibility of the owner/operator to determine loads that can safely be controlled on slopes.
- Transport machine with attachment lowered or close to the ground to improve stability.
- While operating on slopes, drive in an up and down direction when possible. If turning is necessary while driving across slopes, reduce speed and turn slowly in the downhill direction.
- Assure a sufficient supply of fuel for continuous operation. A minimum of one-half tank of fuel is recommended.

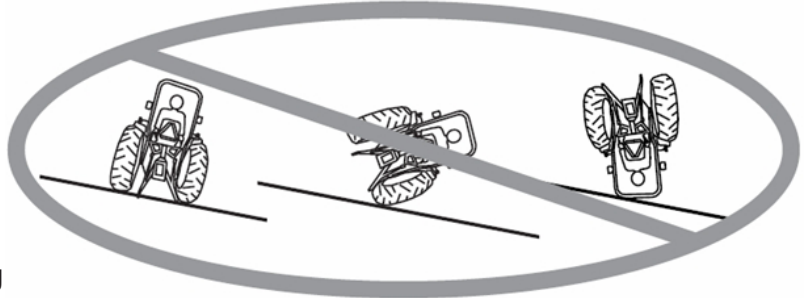

Roadway Safety

- Operate with safety lights when operating on or near roadways.
- Obey all state and local laws concerning operation on roadways.
- Slow down and be careful of traffic when operating near or crossing roadways. Stop before crossing roads or sidewalks. Use care when approaching areas or objects that may obscure vision.
- If there is doubt of safety conditions, discontinue machine operation until a time when operation can be performed safely.
- When operating near or on roadways, have a Slow Moving Vehicle Emblem clearly displayed.

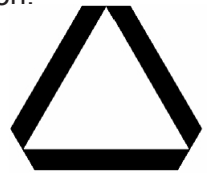

Truck Or Trailer Transport

- Use care when loading or unloading machine into a truck or trailer.
- Use full width ramps for loading machine into a truck or trailer.
- The parking brake is not sufficient to lock the machine during transport. Always secure the power unit and/or attachment to the transporting vehicle securely using straps, chains, cable, or ropes. Both front and rear straps should be directed down and outward from the machine.
- Shut off fuel supply to power unit during transport on truck or trailer.
- If equipped, turn the battery disconnect switch to the Off position to shut off electrical power.

SAFETY



General Safety Procedures for Ventrac Power Units, Attachments, & Accessories



Maintenance

- Keep all safety decals legible. Remove all grease dirt, and debris from safety decals and instructional labels.
- If any decals are faded, illegible, or missing, contact your dealer promptly for replacements.
- When new components are installed, be sure that current safety decals are affixed to the replacement components.
- If any component requires replacement, use only original Ventrac replacement parts.
- Always turn the battery disconnect to the Off position or disconnect the battery before performing any repairs. Disconnect the negative terminal first and the positive terminal last. Reconnect the positive terminal first and the negative terminal last.
- Keep all bolts, nuts, screws, and other fasteners properly tightened.
- Always lower the attachment to the ground, engage parking brake, shut off engine, and remove the ignition key. Make sure all moving parts have come to a complete stop before cleaning, inspection, adjusting or repairing.
- If the power unit, attachment, or accessory requires repairs or adjustments not instructed in the operator's manual, the power unit, attachment, or accessory must be taken to an authorized Ventrac dealer for service.
- Never perform maintenance on the power unit and/or attachment if someone is sitting in the operator's seat.
- Always use protective glasses when handling the battery.
- Check all fuel lines for tightness and wear on a regular basis. Tighten or repair them as needed.
- To reduce the hazard of fire, keep the battery compartment, engine, and muffler areas free of grass, leaves, and excessive grease.
- Do not touch the engine, the muffler, or other exhaust components while the engine is running or immediately after stopping the engine. These areas may be hot enough to cause a burn.
- Allow the engine to cool before storing and do not store near an open flame.
- Do not change the engine governor settings or over-speed the engine. Operating engine at excessive speed may increase the hazard of personal injury.
- Springs may contain stored energy. Use caution when disengaging or removing springs and/or spring loaded components.
- An obstruction or blockage in a drive system or moving/rotating parts may cause a buildup of stored energy. When the obstruction or blockage is removed, the drive system or moving/rotating parts may move suddenly. Do not attempt to remove an obstruction or blockage with your hands. Keep hands, feet, and clothing away from all power-driven parts.
- Dispose of all fluids in accordance with local laws.

Fuel Safety



- To avoid personal injury or property damage, use extreme care in handling gasoline. Gasoline is extremely flammable and the vapors are explosive.
- Do not refuel machine while smoking or at a location near flames or sparks.
- Always refuel the machine outdoors.
- Do not store machine or fuel container indoors where fumes or fuel can reach an open flame, spark, or pilot light.
- Only store fuel in an approved container. Keep out of reach of children.
- Never fill containers inside a vehicle or on a truck or trailer bed with a plastic liner. Always place containers on the ground away from your vehicle before filling.
- Remove machine from the truck or trailer and refuel it on the ground. If this is not possible, refuel the machine using a portable container, rather than from a fuel dispenser nozzle.
- Never remove fuel cap or add fuel with the engine running. Allow engine to cool before refueling.
- Never remove fuel cap while on a slope. Only remove when parked on a level surface.
- Replace all fuel tank and container caps securely.

SAFETY



General Safety Procedures for Ventrac Power Units, Attachments, & Accessories



Fuel Safety (continued)

- Do not overfill fuel tank. Only fill to bottom of fuel neck, do not fill fuel neck full. Overfilling of fuel tank could result in engine flooding, fuel leakage from the tank, and/or damage to the emissions control system.
- If fuel is spilled, do not attempt to start the engine. Move the power unit away from the fuel spill and avoid creating any source of ignition until fuel vapors have dissipated.
- If the fuel tank must be drained, it should be drained outdoors into an approved container.
- Dispose of all fluids in accordance with local laws.
- Check all fuel lines for tightness and wear on a regular basis. Tighten or repair them as needed.
- The fuel system is equipped with a shut-off valve. Shut off the fuel when transporting the machine to and from the job, when parking the machine indoors, or when servicing the fuel system.

Hydraulic Safety

- Make sure all hydraulic connections are tight and all hydraulic hoses and tubes are in good condition. Repair any leaks and replace any damaged or deteriorated hoses or tubes before starting the machine.
- Hydraulic leaks can occur under high pressure. Hydraulic leaks require special care and attention.
- Use a piece of cardboard and a magnifying glass to locate suspected hydraulic leaks.



- Keep body and hands away from pinhole leaks or nozzles that eject high pressure hydraulic fluid. Hydraulic fluid escaping under high pressure can penetrate the skin causing serious injury, leading to severe complications and/or secondary infections if left untreated. If hydraulic fluid is injected into the skin, seek immediate medical attention no matter how minor the injury appears.

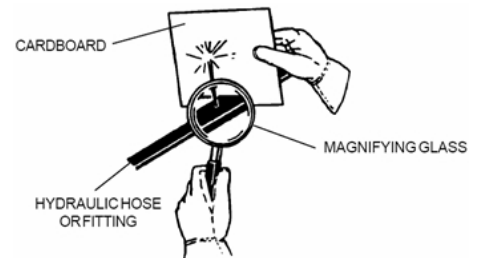

- Hydraulic system may contain stored energy. Before performing maintenance or repairs on the hydraulic system, remove attachments, engage parking brake, disengage weight transfer system (if equipped), shut off engine, and remove ignition key. To relieve pressure on the auxiliary hydraulic system, shut off the power unit engine and move the secondary S.D.L.A. lever left and right before disconnecting the auxiliary hydraulic quick couplers.
- Dispose of all fluids in accordance with local laws.

SAFETY



KV552 V-blade Safety Procedures



- Read and understand the KV552 V-blade operator's manual before operating the V-blade.
- Before making repairs or adjustments to the V-blade, engage the power unit's parking brake, lower the V-blade to the ground, shut off the power unit's engine, and remove the ignition key.
- Always block up the V-blade securely when adjusting the skid shoes.
- Operator's should be familiar with the area they are clearing and make preparations ahead of time. Place guide stakes appropriately and remove stones, markers, or other debris that may be hidden after a snowfall. Curbs, offsets, steps, man hole covers, broken or raised pavement, etc. should be noted. Operator's should map areas to be cleared before the winter season so they can review potential hazards prior to clearing snow in the area.
- If an area is to be cleared that is unfamiliar to the operator, travel slowly and use **EXTREME CAUTION**. Inquire of anyone who might know of potential hazards.
- Never travel at speeds that would cause injury to the operator or damage to the machine if the machine were to be stopped suddenly by an unseen, immovable object.
- Always operate the blade with the safety trip mechanism in the unlocked position, unless digging in dirt at very low speeds.
- Ensure that there are no objects between the back of the blade wings and the power unit. When wings are folded or swept back, objects may be crushed between blade wing and power unit.
- The operator should never proceed if visibility is poor. If the power unit is equipped with a cab, the windshield must be kept clean.
- Use caution when operating around objects that can obstruct your vision.
- Attachment hydraulic system may contain stored energy. Before performing maintenance or repairs on the hydraulic system, the attachment's auxiliary hydraulic hoses must be disconnected from the power unit. Lower the attachment to the ground, shut off the power unit's engine, move the secondary S.D.L.A. lever left and right to relieve auxiliary hydraulic pressure, and disconnect the auxiliary hydraulic quick couplers.

OPERATIONAL CONTROLS

Operational Control Locations

Blade Trip Control

The blade trip control allows the blade to be locked to the frame with a pin or unlocked which allows the blade to trip when the blade hits an immovable object.

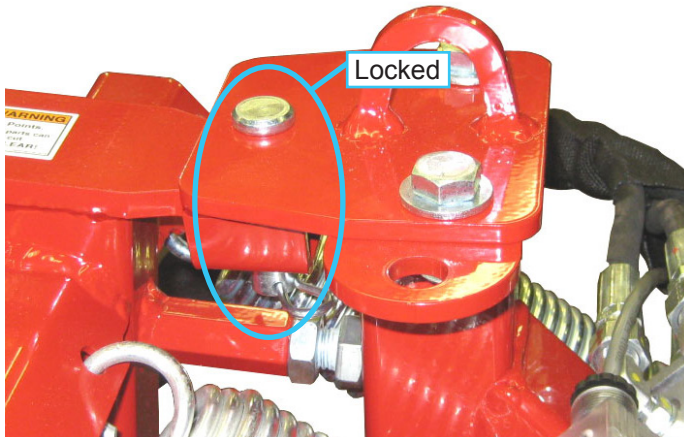
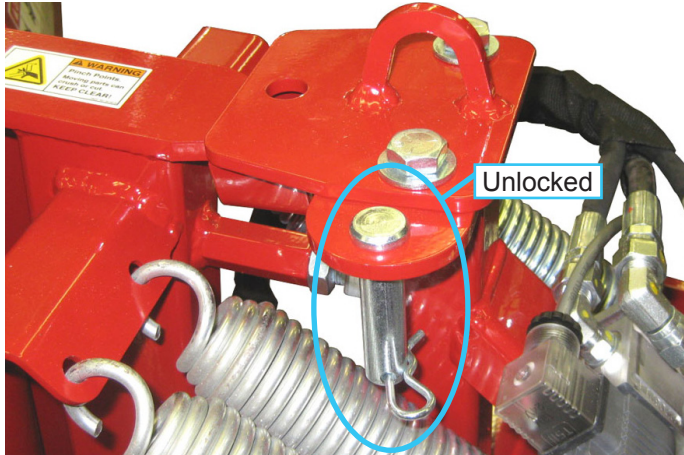

The unlocked position helps prevent sudden stops caused when contact is made with sidewalk joints, rocks, or other immovable objects. The unlocked position should always be used for snow removal. For heavy dozing, the pin can be installed in the lockout hole to lock the blade trip mechanism. This position should only be used for digging or scraping at very slow speeds.

⚠ CAUTION

The V-blade will not trip with the pin in the locked position. Power units with 2 speed transaxles must be operated in low range. The machine must be operated at very slow speed to prevent personal injury or damage to the machine if an immovable object is struck.

Blade Wing Angle (Secondary S.D.L.A. Lever*)

The secondary S.D.L.A. lever* on the power unit controls the angle of the blade wings. The blade wings can be angled independently from 30° forward to 30° backwards. The blade can be angled right and left, swept back, and swept forward.

Blade Wing Selection (12 Volt Switch*)

The 12 volt on/off switch* on the power unit is used to control the 12 volt solenoid valve. The valve controls the selection of the left and right blade wings.

* Refer to power unit operator's manual for operation of power unit controls.

GENERAL OPERATION

Daily Inspection

⚠ WARNING

Always set the parking brake, shut off power unit engine, remove the ignition key, and ensure all moving parts have come to a complete stop before inspecting components, or attempting any repair or adjustment.

1. Park machine on a level surface, with the engine shut off and all fluids cold.
2. Perform a visual inspection of both the power unit and the V-blade. Look for loose or missing hardware, damaged components, or signs of wear. Inspect hydraulic hoses, hydraulic fittings, and fuel lines to ensure tight, leak free connections. Inspect drive belts. Belts should be in good condition.
3. Refer to the power unit operator's manual. Check the power unit's engine oil, hydraulic oil, cooling system, tire pressure, and fuel level. Add fluid or service as required.
4. Inspect the cutting edge and skid shoes for wear and service as required.
5. Test the power unit's operator safety interlock system*.

Attaching

1. Drive the power unit slowly forward into the hitch arms of the V-blade. Align the lift arms of the power unit with the V-blade hitch arms by raising or lowering the front hitch and complete the engagement.
2. Once completely engaged, close the front hitch locking lever.*
3. Engage the parking brake* and shut off the engine.
4. Wipe hose ends clean, and connect to the power unit's hydraulic quick couplers.
5. Connect electric plug.

Detaching

1. Park the power unit on a level surface and set the parking brake.*
2. Angle both blade wings to the back and lower the V-blade to the ground.
3. Shut off power unit engine.
4. Disconnect the hydraulic quick couplers from the power unit and lay the hoses across the frame. Do not allow couplers to lay in dirt or snow.
5. Disconnect the electric plug.
6. Disengage the attachment hitch lock*.
7. Restart the power unit and back slowly away from the V-blade.

Operating Procedure

Before operation, perform daily inspection and verify the skid shoes are set at the desired position.

If weight transfer is used, set the weight transfer so the blade will lower to the ground in the float position.

If power unit is equipped with a 2 speed transaxle, shift the power unit into low range.

Use the 12 volt switch on the power unit to select the desired blade wing and move the secondary S.D.L.A. lever to the left or right to angle the blade wing.

Move the machine into position and lower the V-blade to the ground.

If the skid shoes are used to determine the depth of the blade, place the power unit's primary S.D.L.A. lever in the float position by pushing it to the right until the detent engages. The lever will stay in this position until intentionally removed.

If you are digging or cleaning a hard surface, slight down pressure may be used.

⚠ CAUTION

Using down pressure on the V-blade may reduce the power unit's steering ability. Use only slight down pressure when necessary.

Push the power unit's primary S.D.L.A. lever to the right until there is slight down pressure on the blade and then release.

Drive forward slowly while keeping a close watch for potential hazards.

⚠ WARNING

Never push material at high speeds or attempt to gain momentum and ram material. Sudden deceleration caused by large amounts of material or hidden objects may cause injury to the operator and/or damage to the machine.

When using the V-blade to dig, take shallow cuts and drive slowly.

Back dragging may be used to spread loose material, resulting in a smooth finish. After spreading material over the working area, back the power unit over the area, dragging the blade to smooth and level the material.

* Refer to power unit operator's manual for operation of power unit controls.

GENERAL OPERATION

Transport of V-blade

Transport the V-blade with the power unit front hitch and V-blade raised to reduce wear of the machine and to prevent the V-blade from catching on high spots in the ground, rocks, or other obstacles. Travel slowly when transporting over undulating or rough surfaces to maintain control of power unit and to reduce shock to the machine.

Blade Wing Angle Adjustment

⚠ WARNING

When blade wings are being angled to the back, pinch points are created. Make sure there are no people or objects present between the blade and the power unit.

The blade wings can be angled left or right to push material to the sides. The blade wings can be swept back for single pass clearing of sidewalks and paths. The blade wings can be swept forward to clear areas without the need for repeated clean up passes.

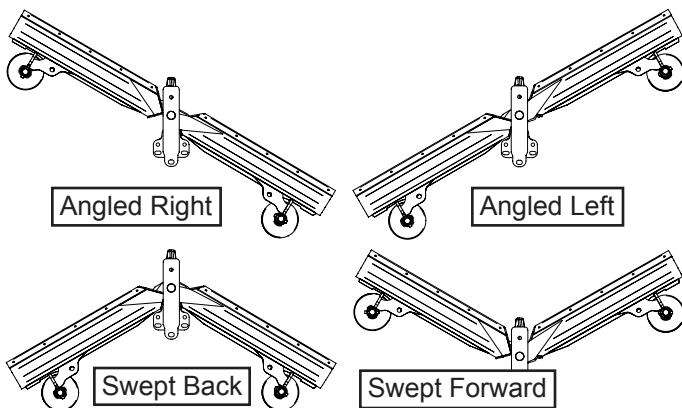

Use the 12 volt switch on the power unit to select the desired blade wing and move the secondary S.D.L.A. lever to the left or right to angle the blade wing.

Resetting the Blade Safety Trip

⚠ WARNING

Pinching Hazard

If V-blade trips, the blade may suddenly return to the operating position. Do not leave the operator's seat or attempt to reset the blade manually.

If the V-blade safety trip is activated but does not reset itself, do not attempt to raise the V-blade. Slowly back the power unit away from the obstacle. The blade will return to the operating position when it is moved away from the obstacle on which it is caught.

Skid Shoe Adjustment

Skid shoes are provided to keep the cutting edge off the surface to be cleared, especially when clearing snow from gravel driveways or roadways.

The skid shoe height is determined by the placement of spacer washers between the skid shoe and the skid shoe mount. Extra spacer washers are stored on top of the skid shoe mount.

1. Determine the number of spacer washers that need to be moved to reach the desired skid shoe height.

⚠ WARNING

When making adjustments with the V-blade in the raised position, the V-blade must be securely supported under the cutting edge with blocks or jack stands.

Hydraulic drift or accidental release of hydraulic pressure could allow the V-blade to lower and trap a person or appendage, if the V-blade is not securely supported.

2. Raise the V-blade to the highest position and adjust the blade wing angle until both wings are perpendicular to the power unit. Support the V-blade securely with blocks or jack stands.
3. Remove the lynch pin (A) and the spacer washers (B) from the top of the skid shoe mount.

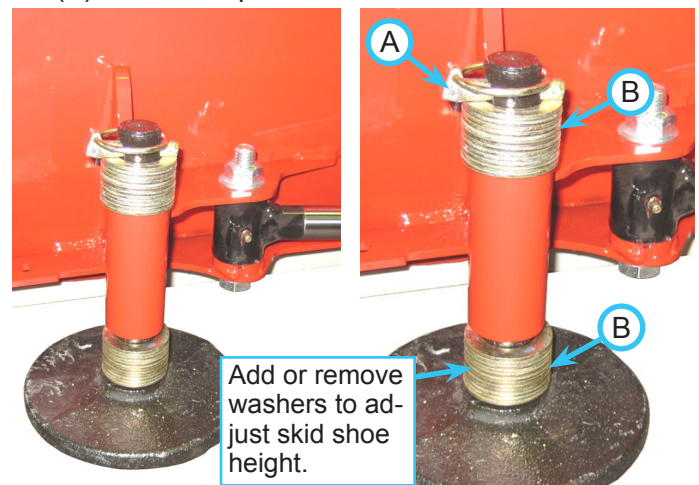

4. Remove the skid shoe from the bottom of the skid shoe mount. Add or remove spacer washers to reach the desired skid shoe height and insert the skid shoe into the skid shoe mount. Place any extra spacer washers on top of the skid shoe mount and fasten the skid shoe in place with the lynch pin. Both the right and left skid shoes should be set at the same height.
5. Remove blocks or jack stands and lower the V-blade to the ground.

SERVICE

⚠ WARNING

Always set the parking brake, shut off power unit engine, remove the ignition key, and ensure all moving parts have come to a complete stop before inspecting components or attempting any repair or adjustment.



Attention

If any component requires replacement, use only original Ventrac replacement parts.

Cleaning and General Maintenance

For best results, and to maintain the finish of the KV552, clean or wash the V-blade to remove dirt, gravel, and salt deposits. Remove any ice or snow accumulations from the blade and frame.



Attention

To maintain the finish of the power unit and attachment, thoroughly wash the equipment after each use to remove any corrosive agents (e.g., salt). Failure to clean the equipment may result in corrosion of (including but not limited to) steel, aluminum, and electrical components. Equipment that will experience repeated exposure to corrosive agents should be pretreated with a corrosion preventative.

Cutting Edge Reversal/Replacement

If the cutting edges wear down near the blade frame structure, remove the cutting edges and flip over so the unworn top edge is now on the bottom. Reinstall the cutting edges onto the V-blade. When both sides of the cutting edges have been worn down, the cutting edges will need to be replaced. Always reverse or replace both cutting edges at the same time.

NOTE: It is normal for the forward edge of the cutting edges to wear faster than the rest of the cutting edge, if the V-blade is used extensively in the swept forward position or in the left and right angled positions. To help minimize this effect, make sure the blade is level from side to side and that the skid shoes are adjusted properly.

Skid Shoe Replacement

Skid shoes should be replaced when wear surface is less than 1/8" thick.

Leveling Blade - Side to Side

1. Make sure the power unit tires are inflated to the correct pressure.

2. With the V-blade attached to the power unit and the power unit parked on a level surface, adjust both wings until they are straight out perpendicular to the power unit.
3. Disengage the power unit's weight transfer system (if equipped).
4. Lower the V-blade to the ground and place the power unit's primary S.D.L.A. lever in the float position by pushing it to the right until the detent engages.
5. Check to see if the cutting edges are making even contact with the ground. If they are not making even contact, raise the blade all the way up and support securely with blocks or jack stands.

⚠ WARNING

When making adjustments with the V-blade in the raised position, the V-blade hitch frame must be supported securely with blocks or jack stands. Hydraulic drift or accidental release of hydraulic pressure could allow the V-blade to lower and trap a person or appendage, if the V-blade is not securely supported.

6. Loosen the 5) 1/2" bolts that fasten the center frame to the center hinge shaft and the center skid shoe.

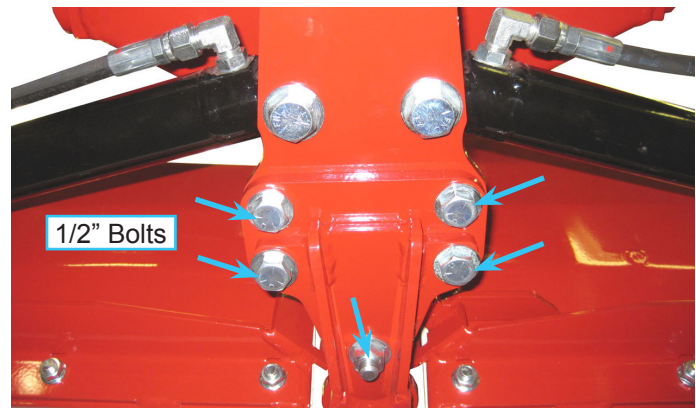

7. Sliding the center frame left or right in relationship to the center hinge shaft will raise or lower the outside corners of the blade wings. Moving the bottom to the right will raise the right side of the blade and lower the left side and moving it to the left will do the opposite. It may be helpful to use a jack or hoist to lift the appropriate side of the blade and then tighten the 1/2" bolts.
8. Repeat steps 4 and 5. If blade is still not level, repeat steps 6 and 7.
9. When the blade is level, tighten the 1/2" bolts to 80 ft-lbs (108 nm).

SERVICE

Leveling Blade - Front to Rear

1. Make sure the blade is level from side to side.
2. With the V-blade attached to the power unit and the power unit parked on a level surface, adjust both wings back into the swept back position.
3. Disengage the power unit's weight transfer system (if equipped).
4. Lower the V-blade to the ground and place the power unit's primary S.D.L.A. lever in the float position by pushing it to the right until the detent engages.
5. Check to see if the cutting edges are making even contact with the ground. If they are not making even contact, loosen the jam nut (A) on the adjusting bolt (B). NOTE: if the blade trip control pin is in the locked position as shown below, it must be removed prior to leveling the blade.

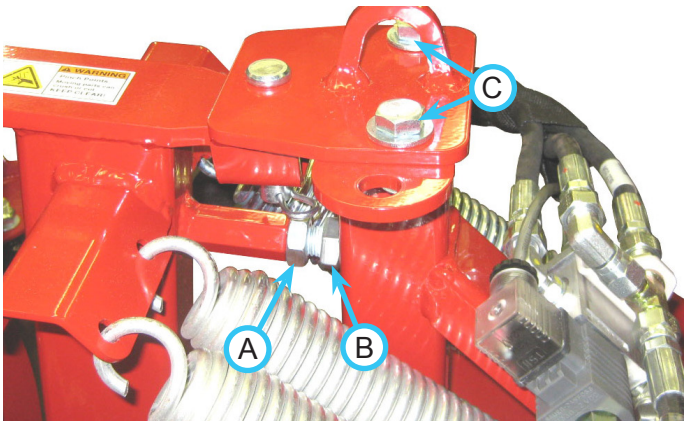

6. Turn the adjusting bolt in to lower the outside corners of the blades and turn the adjusting bolt out to lower the front point of the blade.
7. When the cutting edges are making even contact with the ground, tighten the jam nut to 100 ft-lbs (136 nm).
8. Loosen the 2) 1/2" bolts (C) holding the lockout plate to the hitch frame and slide the plate in the mounting slots until the lockout hole is aligned with the hole in the hitch frame. Use the lockout pin to make sure the holes are aligned and the lockout pin can be installed.
9. Tighten the 1/2" bolts to 80 ft-lbs (108 nm).

Lubrication Locations

Lubrication is required at the following locations using a lithium complex NLGI #2 grease. Refer to the maintenance schedule for service intervals. Grease each joint until fresh grease is visible.

Grease

Spray Lube

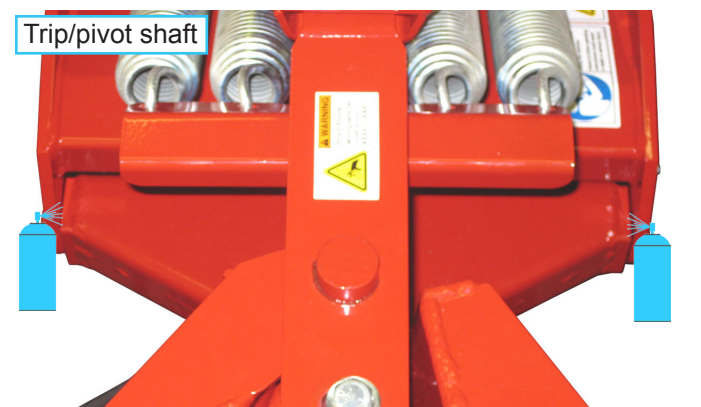
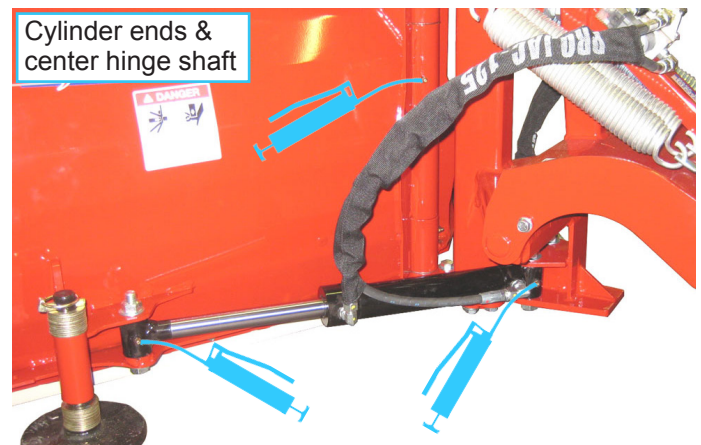
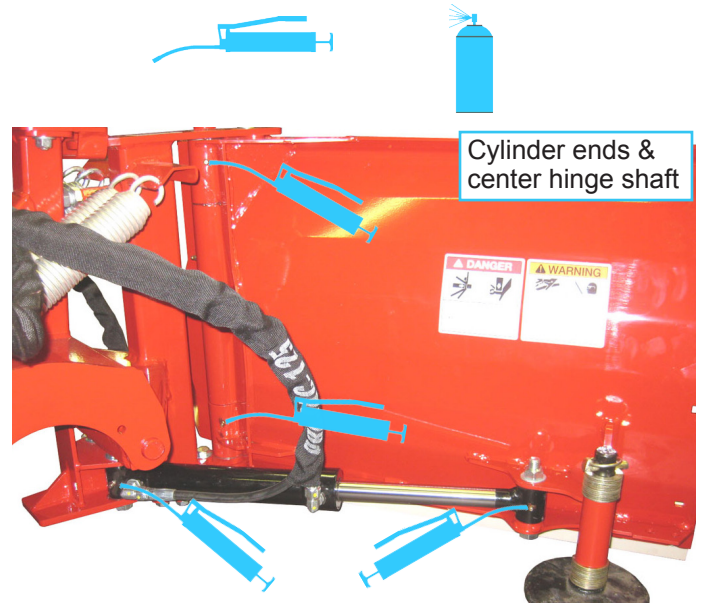

SERVICE

Maintenance Schedule

KV522 V-blade

| Maintenance Schedule | KV522 V-blade | | | | | | | | | | | | | | | | | | | | | | | | | |
|--|----------------|------------|-----------|-------|-------------|--------------|--------------|--------------|--------------|--------------|--------------|--------------|--------------|--------------|--------------|--------------|--------------|--------------|--------------|--------------|--------------|--------------|--------------|---------------|--------|---|
| | # of Locations | # of Pumps | AS NEEDED | Daily | At 50 Hours | At 100 Hours | At 150 Hours | At 200 Hours | At 250 Hours | At 300 Hours | At 350 Hours | At 400 Hours | At 450 Hours | At 500 Hours | At 550 Hours | At 600 Hours | At 650 Hours | At 700 Hours | At 750 Hours | At 800 Hours | At 850 Hours | At 900 Hours | At 950 Hours | At 1000 Hours | Yearly | |
| Grease & Lubrication: See Lubrication Section | | | | | | | | | | | | | | | | | | | | | | | | | | |
| Cylinder End Pivots | 4 | ^ | ** | | ✓ | ✓ | ✓ | ✓ | ✓ | ✓ | ✓ | ✓ | ✓ | ✓ | ✓ | ✓ | ✓ | ✓ | ✓ | ✓ | ✓ | ✓ | ✓ | ✓ | ✓ | ✓ |
| Center Hinge Shaft | 3 | ^ | ** | | ✓ | ✓ | ✓ | ✓ | ✓ | ✓ | ✓ | ✓ | ✓ | ✓ | ✓ | ✓ | ✓ | ✓ | ✓ | ✓ | ✓ | ✓ | ✓ | ✓ | ✓ | ✓ |
| Trip/Pivot Shaft | 2 | & | ** | | ✓ | ✓ | ✓ | ✓ | ✓ | ✓ | ✓ | ✓ | ✓ | ✓ | ✓ | ✓ | ✓ | ✓ | ✓ | ✓ | ✓ | ✓ | ✓ | ✓ | ✓ | ✓ |
| Inspection | | | | | | | | | | | | | | | | | | | | | | | | | | |
| Inspect for Loose, Missing, or Worn Components. | | | | ✓ | | | | | | | | | | | | | | | | | | | | | | |
| Inspect Cutting Edges, Skid Shoes, Center Runner Skid Shoe, Fittings, Hydraulic Hoses, and Electric Cord | | | | ✓ | | | | | | | | | | | | | | | | | | | | | | |
| Inspect Safety Decals | | | | ✓ | | | | | | | | | | | | | | | | | | | | | | |
| ** Operation in severe conditions may require more frequent service intervals. | | | | | | | | | | | | | | | | | | | | | | | | | | |
| ^ Grease until fresh grease is visible. | | | | | | | | | | | | | | | | | | | | | | | | | | |
| & Spray Lubricant | | | | | | | | | | | | | | | | | | | | | | | | | | |

Maintenance Checklist

KV522 V-blade

| Maintenance Checklist | KV522 V-blade | | | | | | | | | | | | | | | | | | | | | | | | | |
|--|----------------|------------|-------------|--------------|--------------|--------------|--------------|--------------|--------------|--------------|--------------|--------------|--------------|--------------|--------------|--------------|--------------|--------------|--------------|--------------|--------------|---------------|--------|--|--|--|
| | # of Locations | # of Pumps | At 50 Hours | At 100 Hours | At 150 Hours | At 200 Hours | At 250 Hours | At 300 Hours | At 350 Hours | At 400 Hours | At 450 Hours | At 500 Hours | At 550 Hours | At 600 Hours | At 650 Hours | At 700 Hours | At 750 Hours | At 800 Hours | At 850 Hours | At 900 Hours | At 950 Hours | At 1000 Hours | Yearly | | | |
| Grease & Lubrication: See Lubrication Section | | | | | | | | | | | | | | | | | | | | | | | | | | |
| Cylinder End Pivots | 4 | ^ | | | | | | | | | | | | | | | | | | | | | | | | |
| Center Hinge Shaft | 3 | ^ | | | | | | | | | | | | | | | | | | | | | | | | |
| Trip/Pivot Shaft | 2 | & | | | | | | | | | | | | | | | | | | | | | | | | |
| Inspection | | | | | | | | | | | | | | | | | | | | | | | | | | |
| Inspect for Loose, Missing, or Worn Components. | | | | | | | | | | | | | | | | | | | | | | | | | | |
| Inspect Cutting Edges, Skid Shoes, Center Runner Skid Shoe, Fittings, Hydraulic Hoses, and Electric Cord | | | | | | | | | | | | | | | | | | | | | | | | | | |
| Inspect Safety Decals | | | | | | | | | | | | | | | | | | | | | | | | | | |
| ** Operation in severe conditions may require more frequent service intervals. | | | | | | | | | | | | | | | | | | | | | | | | | | |
| ^ Grease until fresh grease is visible. | | | | | | | | | | | | | | | | | | | | | | | | | | |
| & Spray Lubricant | | | | | | | | | | | | | | | | | | | | | | | | | | |

SPECIFICATIONS

Dimensions

| | |
|---|---|
| Overall Height | 24 inches (60.9 cm) |
| Overall Width | 55 inches (139.7 cm) |
| | with Blade Wings Swept Forward - 48.5 inches (123.2 cm) |
| | with Blade Wings Swept Back - 48 inches (121.9 cm) |
| Overall Length | 36 inches (91.5 cm) |
| | with KT 4000 series power unit - 109 inches (276.9 cm) |
| | with LE 3000 series power unit - 99.5 inches (252.7 cm) |
| Weight | 270 pounds (122.5 kg) |
| Blade Wing Angle - Forward and Backward | 30 degrees |

Features

- Independent right and left blade movement is controlled by separate cylinders
- Electric solenoid selects which blade will move
- Adjustable skid shoes
- Spring controlled blade safety trip mechanism
- Blade safety trip lockout for pushing dirt
- Reversible and changeable cutting edge

PARTS

ILLUSTRATED DRAWING Blade Wings, Cutting Edge, & Skid Shoes

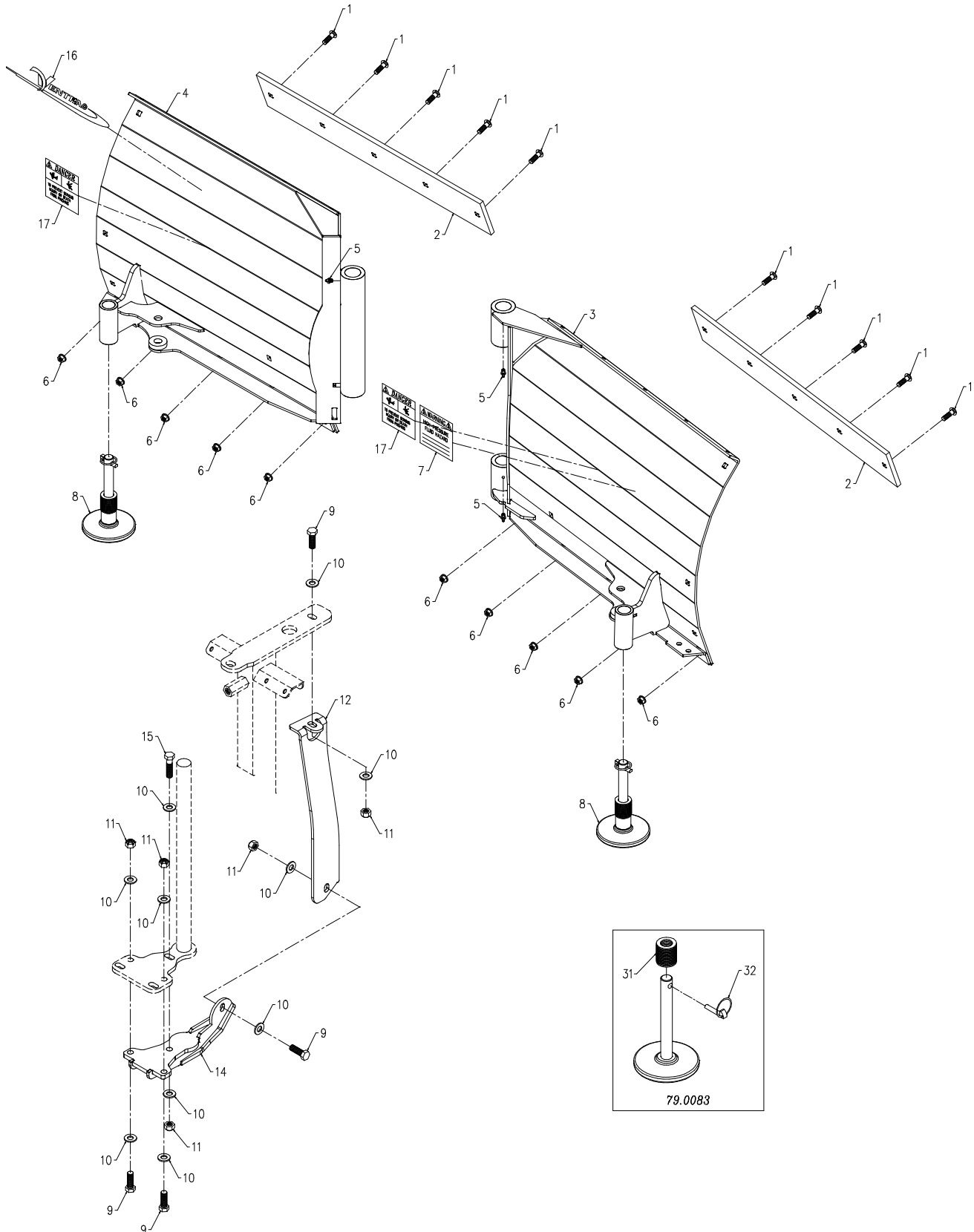

PARTS

Blade Wings, Cutting Edge, & Skid Shoes

| REF. | PART NO. | DESCRIPTION | QTY. |
|------|-----------|---------------------------------|------|
| 1 | 97.0610 | .BOLT, CARRIAGE 3/8 X 1 1/4 | 10 |
| 2 | 78.0055 | .CUTTING EDGE, 3/8 X 4 X 26L | 2 |
| 3 | 62.1329 | .FRAME, WING RIGHT KV552 | 1 |
| 4 | 62.1330 | .FRAME, WING LEFT KV552 | 1 |
| 5 | 29.GF0001 | .GREASE FTG, 1/4 SAE ST | 3 |
| 6 | 99.SF06 | .NUT, SRF 3/8-16 USS | 10 |
| 7 | 00.0103 | .DECAL, HAZARD-HIGH PRESS.FLUID | 1 |
| 8 | 79.0083 | .SHOE, SKID ROUND ASM | 2 |
| 9 | 90.0812 | .BOLT, 1/2-13 USS X 1 1/2 | 4 |
| 10 | 95.08 | .WASHER, FLAT 1/2 SAE | 10 |
| 11 | 99.A08 | .LOCKNUT, STOVER 1/2-13 USS | 5 |
| 12 | 64.1492 | .BRACE, CENTER SKID SHOE | 1 |
| 14 | 64.1486 | .SHOE, SKID CENTER RUNNER | 1 |
| 15 | 90.0816 | .BOLT, 1/2-13 USS X 2 | 1 |
| 16 | 00.0189 | .DECAL, VENTRAC ORBITAL | 1 |
| 17 | 00.0102 | .DECAL, DANGER-PINCHING HAZARD | 2 |
| 31 | 03.0005 | .PIN, LYNCH | 1 |
| 32 | 95.16 | .WASHER, FLAT 1 SAE | 19 |

PARTS

ILLUSTRATED DRAWING Center Frame & Hitch Frame

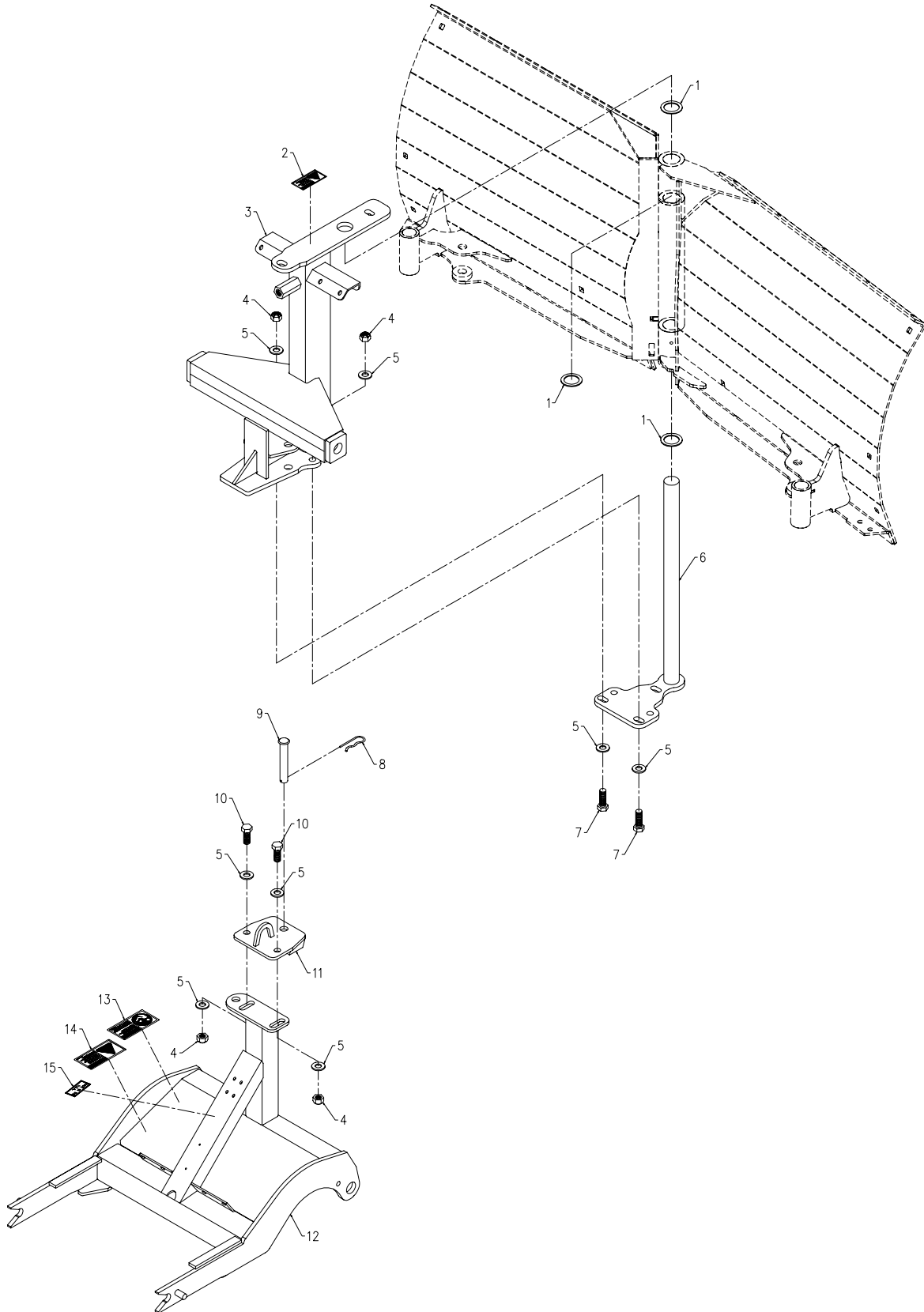

PARTS

Center Frame & Hitch Frame

| REF. | PART NO. | DESCRIPTION | QTY. |
|------|-----------|----------------------------------|------|
| 1 | 99.B0078 | .WASHER, MACH 1 1/4 14 GA | 3 |
| 2 | 00.0218 | .DECAL, WARNING PINCH POINT | 1 |
| 3 | 62.1252 | .FRAME, CENTER SUBFRAME | 1 |
| 4 | 99.A08 | .LOCKNUT, STOVER 1/2-13 USS | 4 |
| 5 | 95.08 | .WASHER, FLAT 1/2 SAE | 8 |
| 6 | 80.0351 | .SHAFT, CENTER HINGE KV | 1 |
| 7 | 90.0812 | .BOLT, 1/2-13 USS X 1 1/2 | 2 |
| 8 | 02.HP0416 | .HAIRPIN, 1/8 X 2 | 1 |
| 9 | 03.1020 | .CLEVIS PIN, 5/8 X 2 1/2 | 1 |
| 10 | 90.0810 | .BOLT, 1/2-13 USS X 1 1/4 | 2 |
| 11 | 64.1134 | .PLATE, TRIP LOCK | 1 |
| 12 | 62.1024 | .FRAME, HITCH KV550 | 1 |
| 13 | 00.0217 | .DECAL, WARNING READ OWNERS MAN. | 1 |
| 14 | 00.0220 | .DECAL, GENERAL SAFETY | 1 |
| 15 | 00.0100 | .DECAL, MADE IN USA | 1 |

PARTS

ILLUSTRATED DRAWING Safety Trip Pivot & Springs

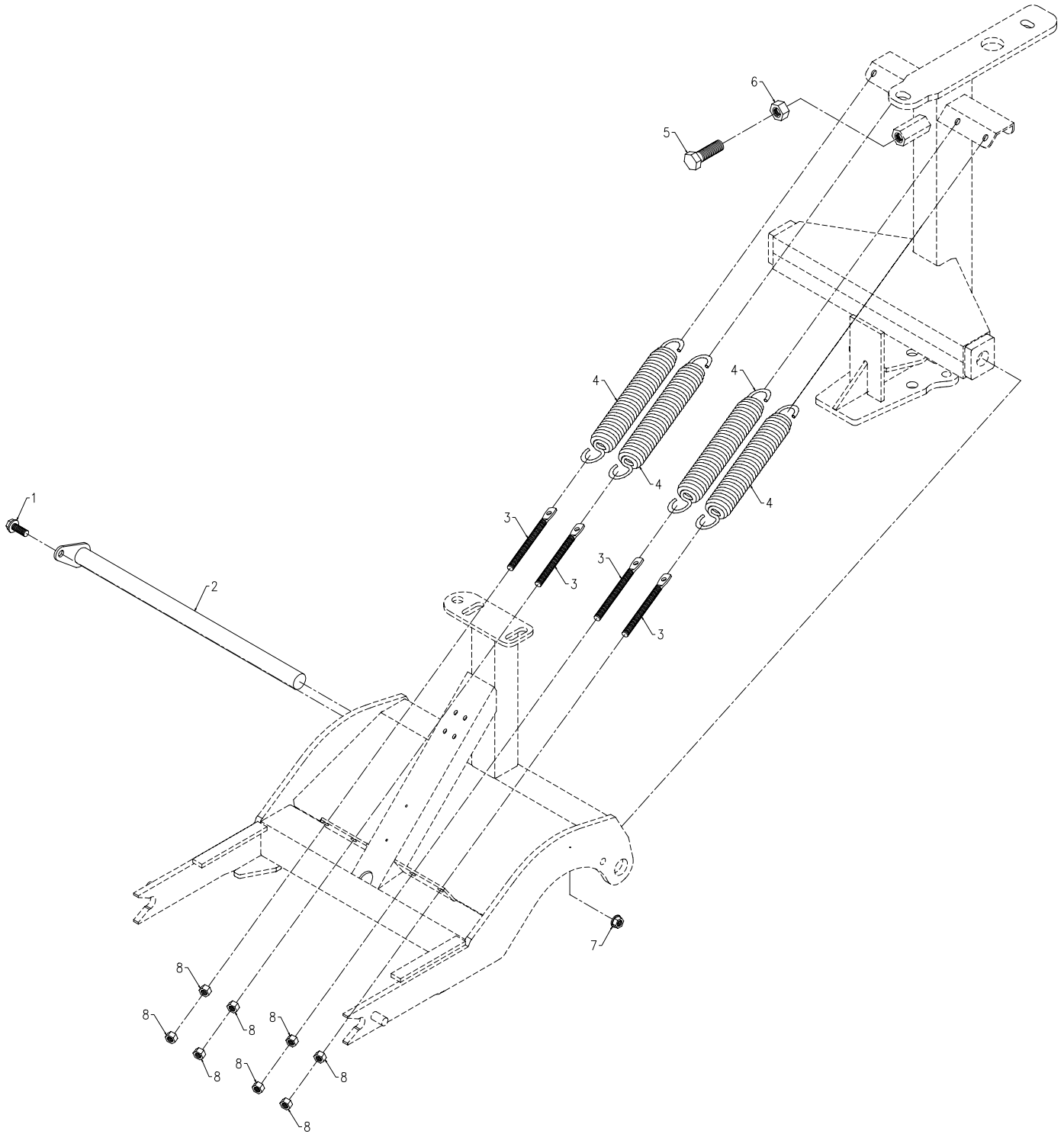

PARTS

Safety Trip Pivot & Springs

| REF. | PART NO. | DESCRIPTION | QTY. |
|------|-----------|--------------------------------|------|
| 1 | 99.SF0608 | .BOLT, SRF 3/8-16 USS X 1 | 1 |
| 2 | 80.0352 | .SHAFT, TRIP/PIVOT | 1 |
| 3 | 99.K0094 | .BOLT, HANGER 3/8-16 X 4 | 4 |
| 4 | 41.0076 | .SPRING, EXT 2" OD X 12-3/8 LG | 4 |
| 5 | 90.1020-2 | .BOLT, 5/8-11 USS X 2-1/2 TAP | 1 |
| 6 | 99.E0076 | .NUT, JAM 5/8-11 USS | 1 |
| 7 | 99.SF06 | .NUT, SRF 3/8-16 USS | 1 |
| 8 | 92.06 | .NUT, 3/8-16 USS | 8 |

PARTS

ILLUSTRATED DRAWING Hydraulic Cylinders, Hoses, & Solenoid Valve

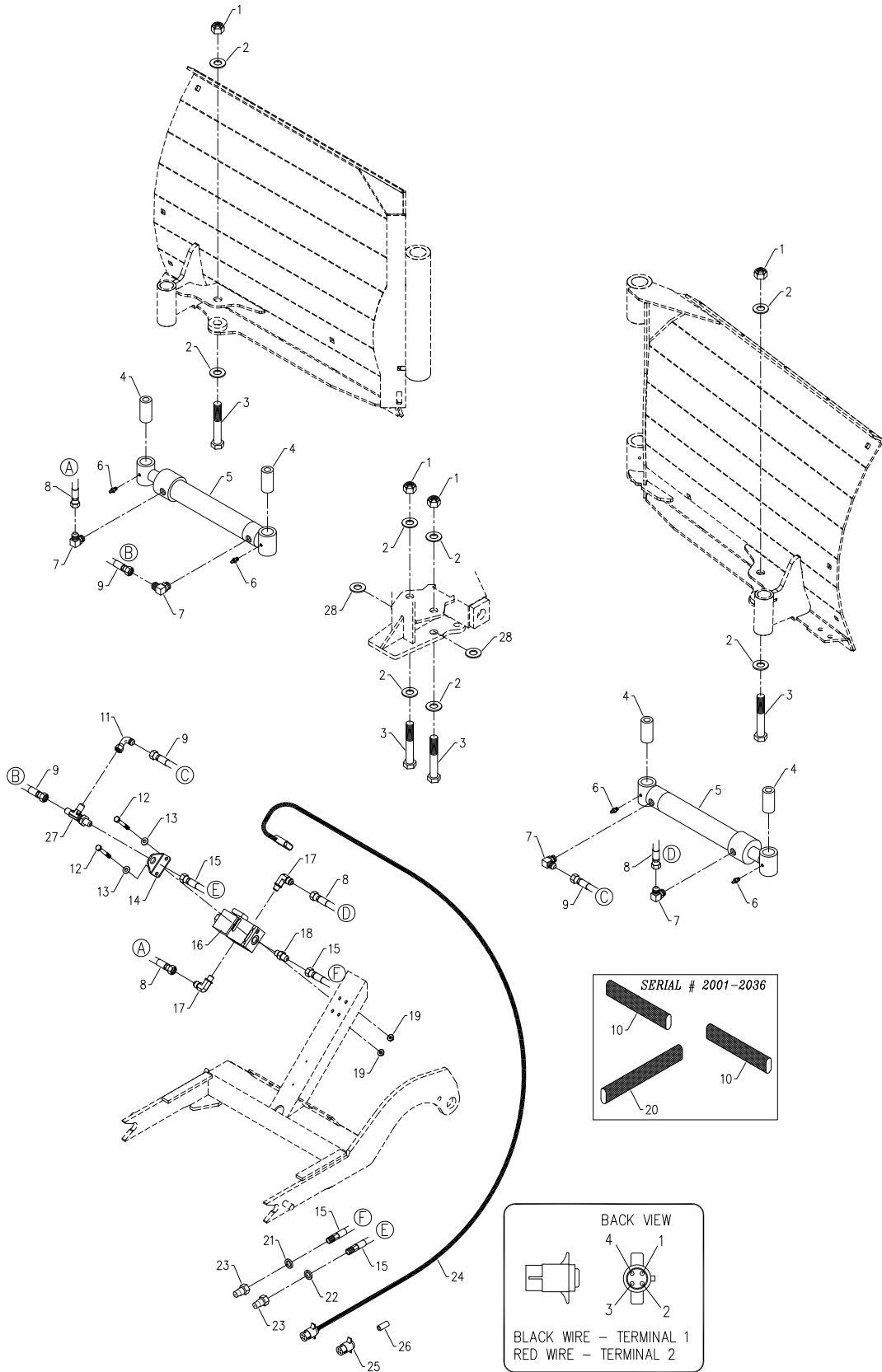

PARTS

Hydraulic Cylinders, Hoses, & Solenoid Valve

| REF. | PART NO. | DESCRIPTION | QTY. |
|------|-----------------|--|-------------|
| 1 | 99.A10 | .LOCKNUT, STOVER 5/8-11 USS | 4 |
| 2 | 95.10 | .WASHER, FLAT 5/8 SAE | 8 |
| 3 | 90.1032 | .BOLT, 5/8-11 USS X 4 | 4 |
| 4 | 64.1248 | .BUSHING, 21/32 X 1" X 2-1/16"L | 4 |
| 5 | 23.0137 | .CYLINDER, 1-1/2 X 8 X 1 ROD KV | 2 |
| 6 | 29.GF0001 | .GREASE FTG, 1/4 SAE ST | 4 |
| 7 | 25.6801-06-06 | .FITTING, 90 ME 3/8 X 3/8 | 4 |
| 8 | 20.0112 | .HOSE, 1/4X28.00 SAE 100R17AR | 2 |
| 9 | 20.0136 | .HOSE, 1/4X36.00 SAE 100R17 AR | 2 |
| 10 | 56.0060-24 | .SLEEVE, HOSE 1.25 X 24" (Serial # 2001-2036) | 2 |
| 11 | 25.6500-06-06 | .FITTING, 90 MFE 3/8 X 3/8 | 1 |
| 12 | 90.0416 | .BOLT, 1/4-20 USS X 2 | 2 |
| 13 | 95.04 | .WASHER, FLAT 1/4 SAE | 2 |
| 14 | 64.1136 | .BRACKET, HYD BULKHEAD FITTING | 1 |
| 15 | 20.0209 | .HOSE, 1/4X45.00 SAE 100R17 AR | 2 |
| 16 | 23.0136-1 | .VALVE, DIRECTIONAL CONTROL 12V (Serial # 2001-3180) | 1 |
| 16 | 23.0164 | .VALVE, DIRECTIONAL CONTROL 12V (Serial # 3181-) | 1 |
| 17 | 25.6801-06-04 | .FITTING, 90 ME 3/8 X 1/4 (Serial # 2001-3180) | 2 |
| 17 | 25.6801-06-06 | .FITTING, 90 ME 3/8 X 3/8 (Serial # 3181-) | 2 |
| 18 | 25.6400-06-04 | .FITTING, M CONN 3/8 X 1/4 (Serial # 2001-3180) | 1 |
| 18 | 25.6400-06-06 | .FITTING, M CONN 3/8 X 3/8 (Serial # 3181-) | 1 |
| 19 | 99.SF04 | .NUT, SRF 1/4-20 USS | 2 |
| 20 | 56.0060-36 | .SLEEVE, HOSE 1.25 X 36" (Serial # 2001-2036) | 1 |
| 21 | 05.0117 | .WASHER, .544ID X .817 X.14 YEL | 1 |
| 22 | 05.0116 | .WASHER, .544ID X .817 X.14 RED | 1 |
| 23 | 23.0104 | .COUPLER, HYD. QUICK MALE 1/4 | 2 |
| 24 | 34.1400-1011 | .WIRE, 14 GA CORD X 60" (Serial # 2001-3180) | 1 |
| 24 | 32.0171 | .HARNESS, 12V SELECTOR (Serial # 3181-) | 1 |
| 25 | 30.0218 | .PLUG, TRAILER 4-PIN MALE | 1 |
| 26 | 27.A04* | .HOSE, NEOP BLACK 1/4 X 7/16 X 1" (Serial # 2001-3180) | 1 |
| 27 | 25.2704-6-6-6LN | .FITTING, BULKHEAD T 3/8 W/LNUT | 1 |
| 28 | 95.10 | .WASHER, FLAT 5/8 SAE | as required |

*27.A04 is sold by the foot. Specify length when ordering.

PARTS

ILLUSTRATED DRAWING 70.8044 Snow Containment Flap

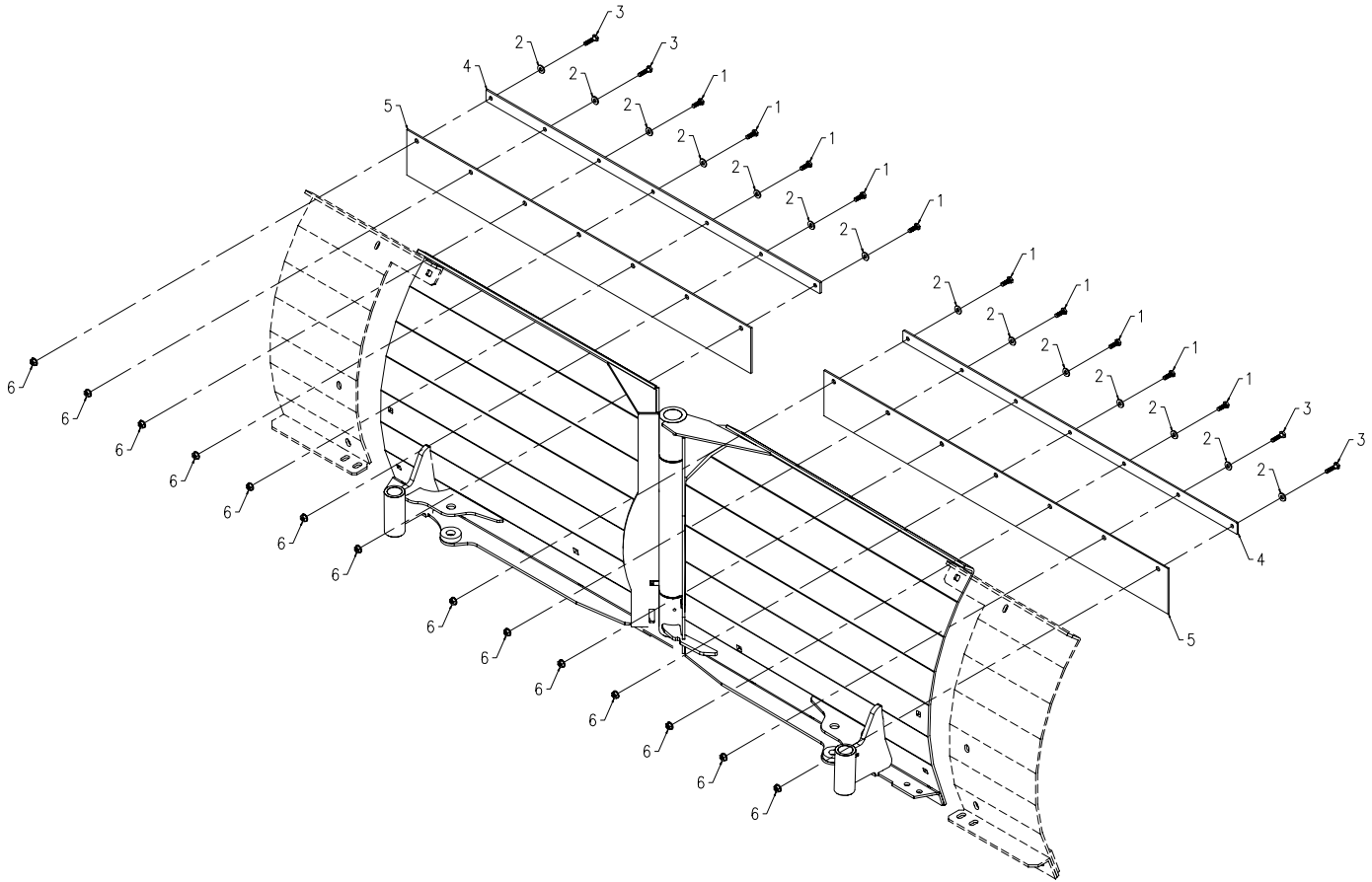

| REF. | PART NO. | DESCRIPTION | QTY. |
|------|----------|---------------------------|------|
| 1 | 90.0406 | .BOLT, 1/4-20 USS X 3/4 | 10 |
| 2 | 95.04 | .WASHER, FLAT 1/4 SAE | 14 |
| 3 | 90.0408 | .BOLT, 1/4-20 USS X 1 | 4 |
| 4 | 64.1143 | .CLAMP, BELTING 34 X 1 | 2 |
| 5 | 44.0216 | .BELTING, SNOW DEFLECTION | 2 |
| 6 | 99.SF06 | .NUT, SRF 3/8-16 USS | 14 |

PARTS

ILLUSTRATED DRAWING 70.8048 Polyurethane Cutting Edge

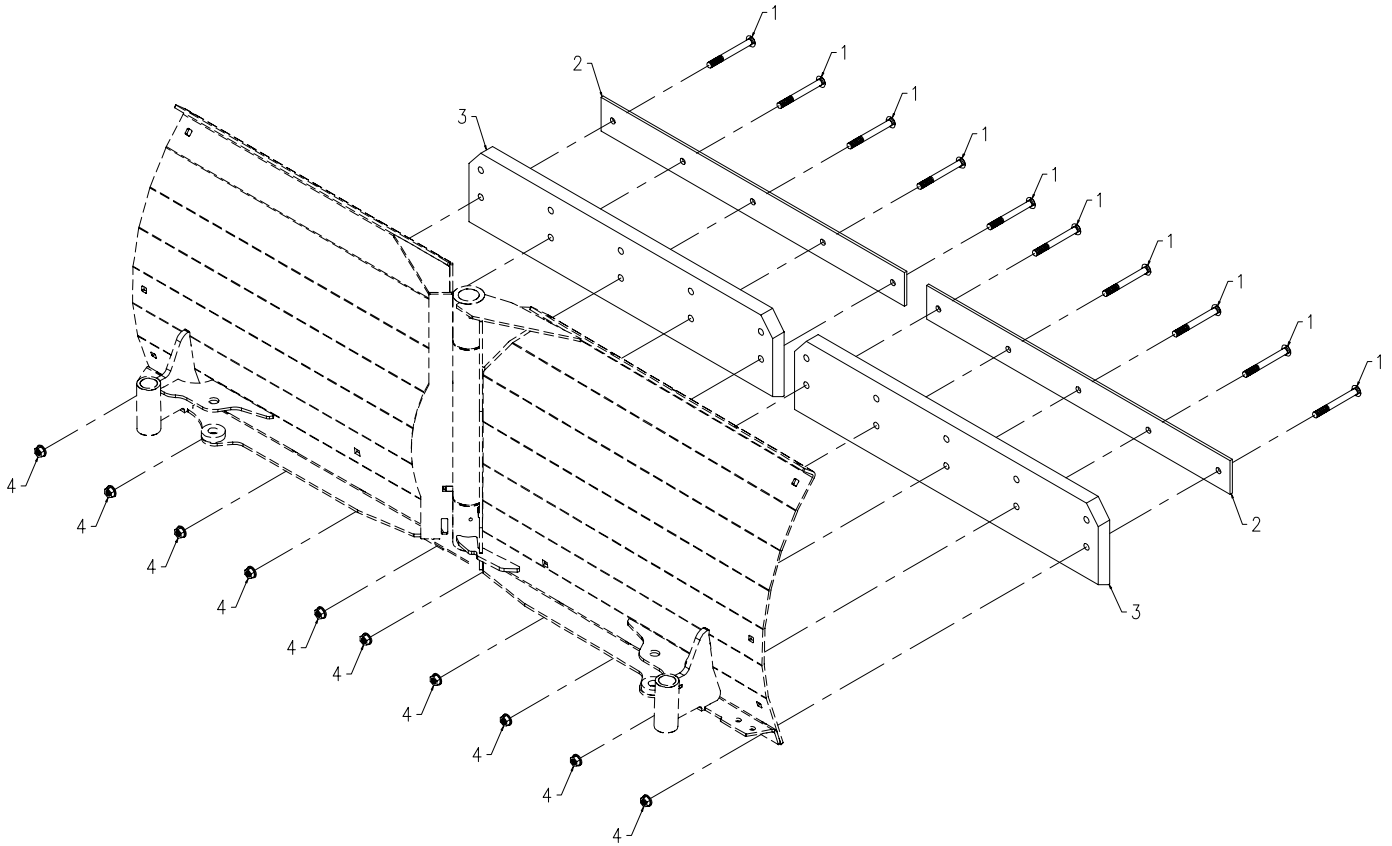

| REF. | PART NO. | DESCRIPTION | QTY. |
|------|----------|---------------------------------|------|
| 1 | 97.0616 | .BOLT, CARRIAGE 3/8 X 2 | 10 |
| 2 | 64.1144 | .CLAMP, POLY BACKER 26L | 2 |
| 3 | 44.0217 | .CUTTING EDGE, POLY 1 X 6 X 26L | 2 |
| 4 | 99.SF06 | .NUT, SRF 3/8-16 USS | 10 |

PARTS

ILLUSTRATED DRAWING 70.8045 6" Top Flare Extension

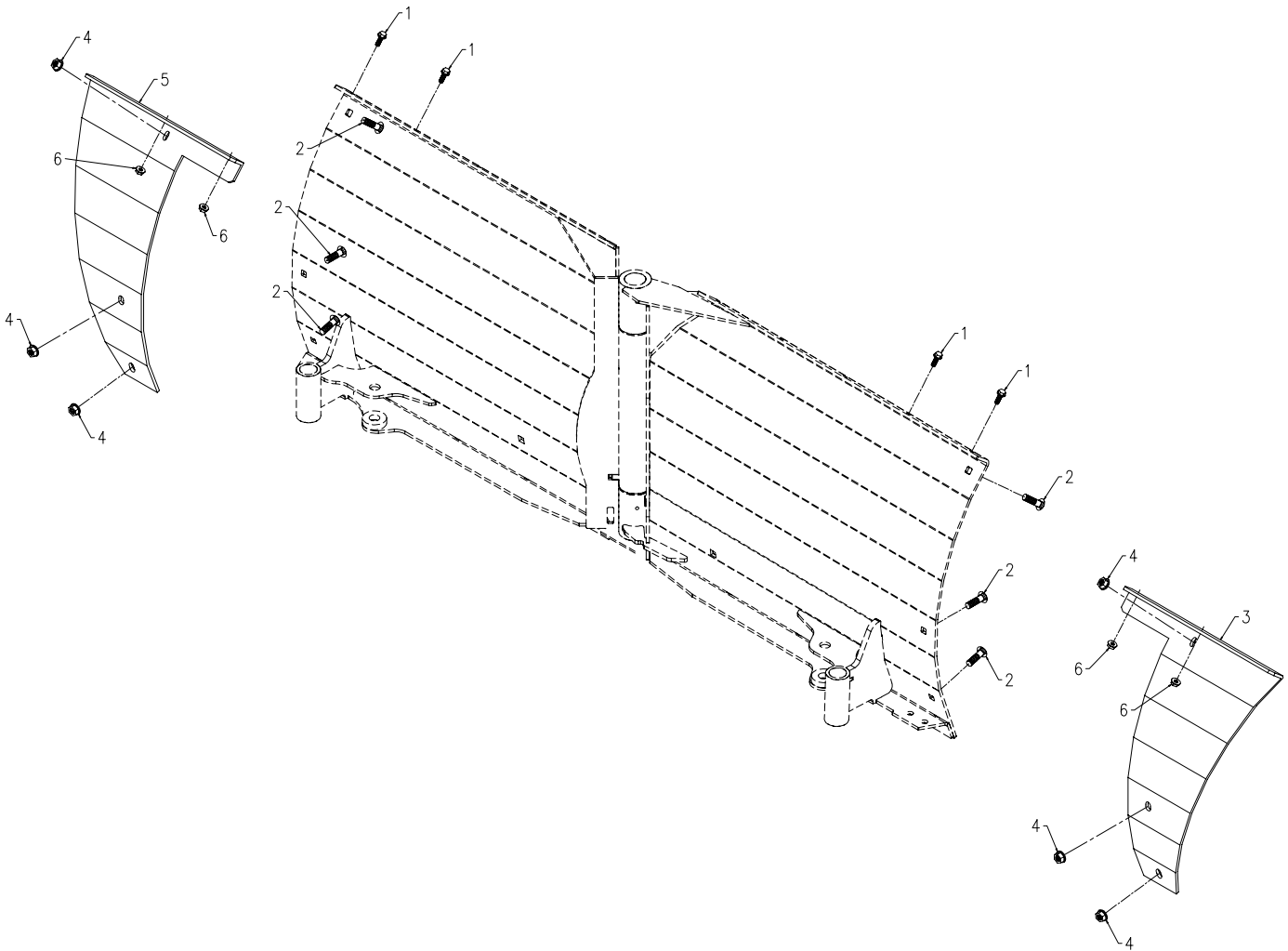

| REF. | PART NO. | DESCRIPTION | QTY. |
|------|-----------|-------------------------|------|
| 1 | 99.SF0406 | .BOLT, SRF 1/4-20 X 3/4 | 4 |
| 2 | 97.0608 | .BOLT, CARRIAGE 3/8 X 1 | 6 |
| 3 | 60.0889 | .EXTENSION, FLARE RH | 1 |
| 4 | 99.SF06 | .NUT, SRF 3/8-16 USS | 6 |
| 5 | 60.0890 | .EXTENSION, FLARE LH | 1 |
| 6 | 99.SF04 | .NUT, SRF 1/4-20 USS | 4 |

PARTS

ILLUSTRATED DRAWING 70.8047 6" Straight Edge Extension

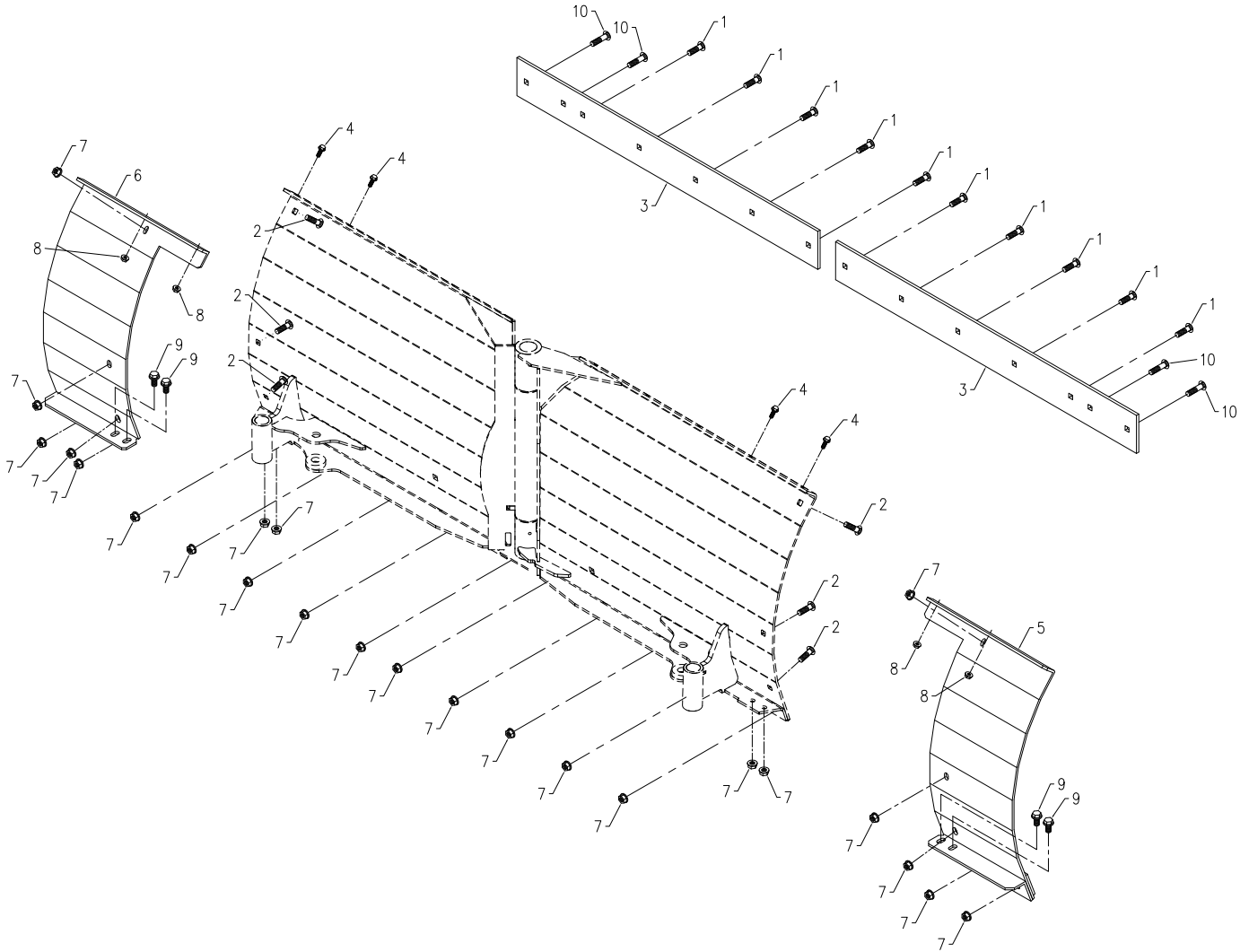

| REF. | PART NO. | DESCRIPTION | QTY. |
|------|-----------|---------------------------------|------|
| 1 | 97.0610 | .BOLT, CARRIAGE 3/8 X 1 1/4 | 10 |
| 2 | 97.0608 | .BOLT, CARRIAGE 3/8 X 1 | 6 |
| 3 | 78.0056 | .CUTTING EDGE, 32" THRU HARD | 2 |
| 4 | 99.SF0406 | .BOLT, SRF 1/4-20 X 3/4 | 4 |
| 5 | 62.1028 | .FRAME, 6" STRAIGHT WING EXT RH | 1 |
| 6 | 62.1029 | .FRAME, 6" STRAIGHT WING EXT LH | 1 |
| 7 | 99.SF06 | .NUT, SRF 3/8-16 USS | 24 |
| 8 | 99.SF04 | .NUT, SRF 1/4-20 USS | 4 |
| 9 | 99.SF0606 | .BOLT, SRF 3/8-16 USS X 3/4 | 4 |
| 10 | 97.0612 | .BOLT, CARRIAGE 3/8 X 1 1/2 | 4 |

PARTS

ILLUSTRATED DRAWING 70.8046 6" Extension with 6" Top Flare

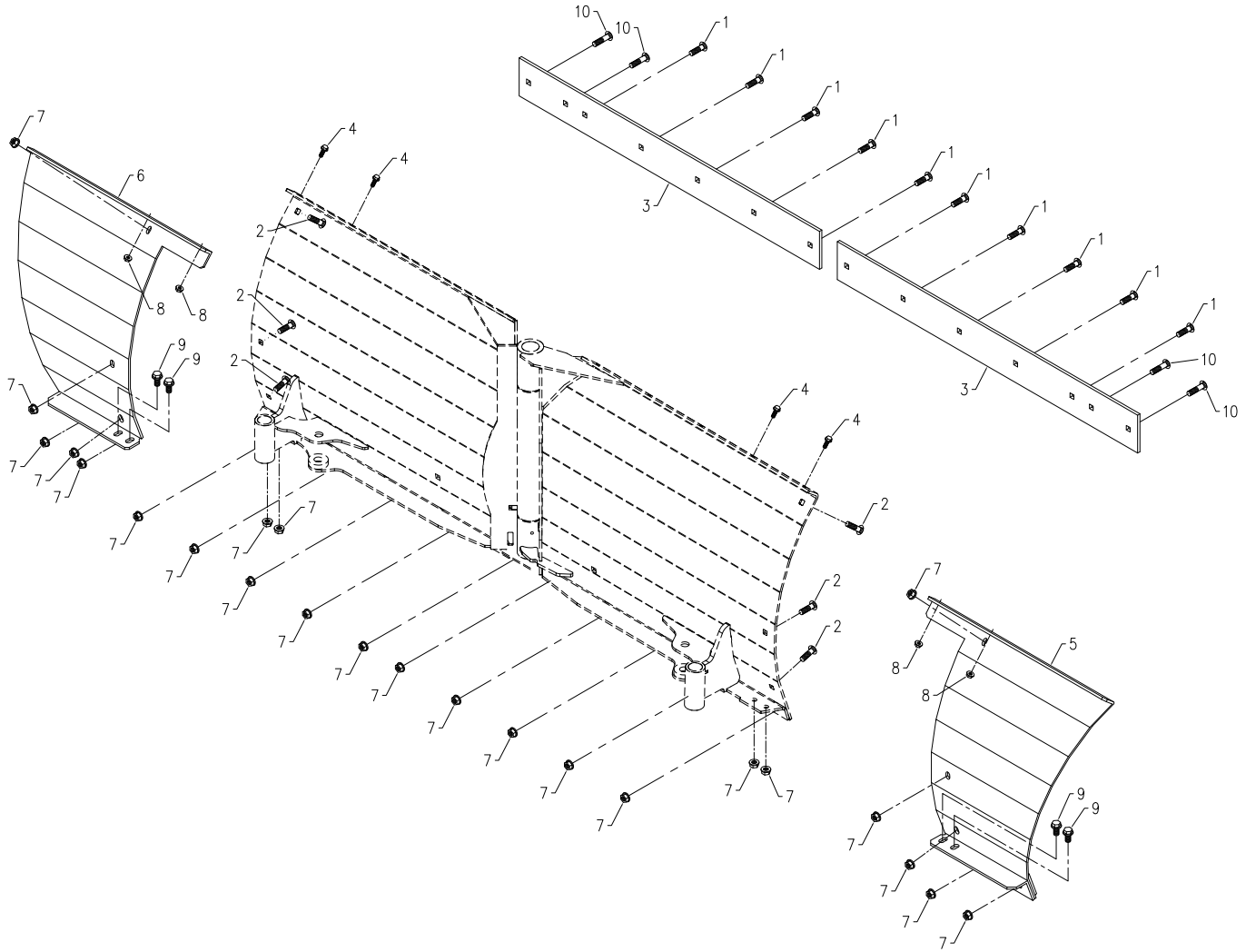

| REF. | PART NO. | DESCRIPTION | QTY. |
|------|-----------|------------------------------|------|
| 1 | 97.0610 | .BOLT, CARRIAGE 3/8 X 1 1/4 | 10 |
| 2 | 97.0608 | .BOLT, CARRIAGE 3/8 X 1 | 6 |
| 3 | 78.0056 | .CUTTING EDGE, 32" THRU HARD | 2 |
| 4 | 99.SF0406 | .BOLT, SRF 1/4-20 X 3/4 | 4 |
| 5 | 62.1030 | .FRAME, 6" FLARE WING EXT RH | 1 |
| 6 | 62.1031 | .FRAME, 6" FLARE WING EXT LH | 1 |
| 7 | 99.SF06 | .NUT, SRF 3/8-16 USS | 24 |
| 8 | 99.SF04 | .NUT, SRF 1/4-20 USS | 4 |
| 9 | 99.SF0606 | .BOLT, SRF 3/8-16 USS X 3/4 | 4 |
| 10 | 97.0612 | .BOLT, CARRIAGE 3/8 X 1 1/2 | 4 |

WARRANTY



LIMITED WARRANTY - VENTRAC TURF EQUIPMENT

Venture Products, Inc. (shall be referred to as V.P.I.) warrants on the terms and conditions herein, that it will repair, replace, or adjust any part manufactured by Venture Products Inc. and found by Venture Products Inc. to be defective in material and / or workmanship.

Effective September 1st 2005, Ventrac warranty on power units & attachments (excluding the HG100/HG150 generator) for **residential use only** is limited to **three (3) years** from original purchase date. Ventrac power units & attachments used **commercially or for any income-producing purpose** is limited to **two (2) years** from original purchase date. Ventrac ET200 turbine blower (turbine only) is limited to **two (2) years** from original purchase date. Ventrac HG100/HG150 generator is limited to **one (1) year** from original purchase date. Ventrac power units & attachments used for **rental** is limited to **180 days** from original purchase date. (NOTE: All accessories such as: 3-point hitch, foot pedal, dual wheel kit, etc. will be covered under the above warranty periods as they would apply provided they are installed by an authorized Ventrac dealer.) This warranty may be transferred and will carry the remainder of the warranty starting from the original purchase/registration date with the dealership and/or V.P.I. In the event that product/s originally registered as **(3) year residential use** are to be transferred to a commercial user, the warranty would change to the remainder of **(2) year commercial use** starting from the original purchase/registration date with the dealership and/or V.P.I.

If this warranty covers a consumer product as defined by the Magnusson-Moss warranty act, no warranties, express or implied, (including, but not limited to, the warranty of merchantability or fitness for a particular purpose) shall extend beyond the applicable time period stated in bold face type above.

If this warranty covers a product used commercially or for any income producing purpose, the foregoing warranties are in lieu of all other warranties and no representations, guarantees or warranties, express or implied, (including, but not limited to, a warranty of merchantability or fitness for a particular purpose), are made by V.P.I. in connection with the manufacture or sale of its products.

The engine warranty is covered by its respective engine manufacturer. Please refer to the engine manufacturer's warranty statement that is included in the owner's manual.

The Ventrac turf equipment, including any defective parts, must be returned to an authorized Ventrac dealer within the warranty period. The warranty shall extend to the cost to repair or replace (as determined by V.P.I.) the defective part. **The expense of pickup and delivery of equipment, service call drive time or any transportation expense incurred for warranty repair is the sole responsibility of the owner and is not covered under warranty by Ventrac and/or V.P.I.** V.P.I.'s responsibility in respect to claims is limited to making the required repairs or replacements, and no claim of breach of warranty shall be cause for cancellation or rescission of the contract of sale of any Ventrac equipment. Proof of purchase may be required by the dealer to substantiate any warranty claim. Only warranty work performed and submitted by an authorized Ventrac dealer may be eligible for warranty credit.

This warranty extends only to Ventrac turf equipment operated under normal conditions and properly serviced and maintained. The warranty expressly does **not** cover: (a) any defects, damage or deterioration due to normal use, wear and tear, or exposure; (b) normal maintenance services, such as cleaning, lubrication, oil change; (c) replacement of service items, such as oil, lubricants, spark plugs, belts, rubber hoses or other items subject to normal service replacement; (d) damage or defects arising out of, or relating to abuse, misuse, neglect, alteration, negligence or accident; (e) repair or replacement arising from operation of, or use of the turf equipment which is not in accordance with operating instructions as specified in the operator's manual or other operational instructions provided by V.P.I.; (f) repair or replacement arising as a result of any operation from Ventrac turf equipment that has been altered or modified so as to, in the determination of V.P.I., adversely affect the operation, performance or durability of the equipment or that has altered, modified or affected the turf equipment so as to change the intended use of the product; (g) repair or replacement necessitated by the use of parts, accessories or supplies, including gasoline, oil or lubricants, incompatible with the turf

WARRANTY



LIMITED WARRANTY - VENTRAC TURF EQUIPMENT

equipment or other than as recommended in the operator's manual or other operational instructions provided by V.P.I.; (h) repairs or replacements resulting from parts or accessories which have adversely affected the operation, performance or durability of the turf equipment; or (i) damage or defects due to or arising out of repair of Ventrac turf equipment by person or persons other than an authorized Ventrac service dealer or the installation of parts other than genuine Ventrac parts or Ventrac recommended parts.

The sole liability of V.P.I. with respect to this warranty shall be repair and replacement as set forth herein. V.P.I. shall have no liability for any other cost, loss, or damage. In particular V.P.I. shall have no liability or responsibility for: (i) expenses relating to gasoline, oil, lubricants; (ii) loss, cost, or expense relating to transportation or delivery of turf equipment from the location of owner or location where used by owner to or from any authorized Ventrac dealer; (iii) travel time, overtime, after hours time or other extraordinary repair charges or charge relating to repairs or replacements outside of normal business hours at the place of business of an authorized Ventrac dealer; (iv) rental of like or similar replacement equipment during the period of any warranty repair or replacement work; (v) any telephone or telegram charges; (vi) loss or damage to person or property other than that covered by the terms of this warranty; (vii) any claims for lost revenue, lost profit or additional cost or expense incurred as a result of a claim of breach of warranty; or (viii) attorney's fees.

The remedies of buyer set forth herein are exclusive and are in lieu of all other remedies. The liability of V.P.I., whether in contract, tort, under any warranty, or otherwise, shall not extend beyond its obligation as set forth herein. V.P.I. shall not be liable for cost of removal or installation nor shall V.P.I. be responsible for any direct, indirect, special or consequential damages of any nature. In no event shall V.P.I. be liable for any sum in excess of the price received for the goods for which liability is claimed.

There are no representations or warranties which have been authorized to the buyer of the turf equipment other than set forth in this warranty. Any and all statements or representations made by any seller of this equipment, including those set forth in any sales literature or made orally by any sales representative, are superseded by the terms of this warranty. Any affirmation of fact or promise made by V.P.I. or any of its representatives to the buyer which relates to the goods that are the subject to this warranty shall not be regarded as part of the basis of the bargain and shall not be deemed to create any express warranty that such goods shall conform to the affirmation or promise.

No employee, distributor, or representative is authorized to change the foregoing warranties in any way or grant any other warranty on behalf of V.P.I.

Some states do not allow limitations on how long an implied warranty lasts or allow the exclusion on limitation of incidental or consequential damages, so the above limitation or exclusion may not apply to you.

This warranty gives you specific legal rights, and you may also have other rights which vary from state to state.

This warranty applies to all Ventrac turf equipment sold in the United States and Canada.